

NICKEL INSTITUTE

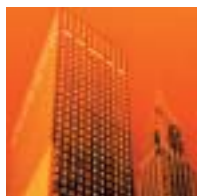

TIMELESS STAINLESS  
ARCHITECTURE



**Nickel  
Institute**

Reference Book  
Series No 11 023

# Timeless Stainless Architecture

Foreground: 150 E. 42nd Street, 1954 Background: Chrysler Building, 1930



The material presented in this publication has been prepared for the general information of the reader and should not be used or relied upon for specific applications without first securing competent advice.

Nickel Institute, its members, staff, and consultants do not represent or warrant its suitability for any general or specific use and assume no liability or responsibility of any kind in connection with the information herein. Drawings and/or photographs of equipment, machinery, and products are for illustrative purposes only, and their inclusion does not constitute or imply any endorsement of the companies that manufacture or distribute them.

This report was prepared by C. Houska, Technical Marketing Resources, Pittsburgh, PA, USA, P.G. Stone and D.J. Cochrane, United Kingdom. All are consultants to the Nickel Institute.

*The front cover shows two New York City landmarks, the Chrysler Building and 150 East 42nd Street (formerly the Socony Mobil Building), after they were cleaned in 1995. (Courtesy of Allegheny Ludlum Corporation)*

# Table of Contents

INTRODUCTION .....	2
ENVIRONMENTAL BENEFIT OF STAINLESS STEEL .....	3
SELECTION .....	4
Table 1: Suggested Stainless Steels for Common Exterior Environments .....	4
MAINTENANCE AND FINISH SELECTION .....	5
Table 2: International Cold-Rolled Sheet and Strip Surface Finish Cross Reference .....	6
Table 3: Typical Surface Roughness Ranges From North American Stainless Steel Suppliers .....	7
SAVOY HOTEL, 1929 .....	8
CHRYSLER BUILDING, 1930 .....	10
EMPIRE STATE BUILDING, 1931 .....	12
GENERAL ELECTRIC TURBINE PLANT, BUILDING NO. 273, 1948 ..	14
150 EAST 42ND STREET, 1954 .....	16
DAS THYSSENHAUS, 1960 .....	18
PITTSBURGH CIVIC ARENA, 1961 .....	20
ELEPHANT & CASTLE SUB-STATION, 1962 .....	22
GATEWAY ARCH, 1965 .....	24
LEWISHAM CIVIC CENTRE, 1971 .....	26
KEARNS COMMUNICATIONS GROUP BUILDING, 1973 .....	28
ENFIELD CIVIC CENTRE, 1973 .....	30
PIER PAVILION, 1976 .....	32
ICI BUILDING, 1981 .....	34
SUN LIFE CENTRE, 1984 .....	36
MICHAEL FOWLER CENTRE, 1985 .....	38
ACKNOWLEDGEMENTS .....	40
NiDI ARCHITECTURAL LITERATURE .....	41

# Introduction



Shortly after their development, austenitic stainless steels were embraced as important architectural design materials. The first large architectural applications were in the tallest buildings in the world, the Chrysler and Empire State. Other high-profile projects quickly followed and stainless steel became the preeminent material for projecting a progressive, modern image.

In the 1920's, stainless steel was made in very small quantities, quality was inconsistent, and finish options were limited. Modern stainless steels are produced in large volumes, the real cost of stainless steel has decreased, and quality is consistent and high. Today's architects and designers can choose from many more stainless steel grades and numerous finish options including colour and texture. Architects are attracted to stainless steel's atmospheric corrosion and wear resistance, strength, durability, cleanability, range of finishes, and product forms. Any product form desired can be obtained in stainless steel including structural components, precision castings, wire, cloth, panels, and tubular products.

Buildings designed to last fifty or more years use nickel stainless steels for a broader range of interior and exterior applications because, with appropriate selection and care, they last for the life of the building and are cost-effective, attractive, and relatively low maintenance. Buildings with shorter service lives need durable materials for high-traffic areas, public bathrooms, security-related applications, and similar applications to avoid costly and disruptive renovation or replacement.

This brochure describes sixteen noteworthy, international, exterior stainless steel architectural applications that were completed between 1929 and 1985. At least one example is provided from every decade. These buildings and structures represent a range of applications and service environments. Some have had regular maintenance and others have had none. All illustrate the exceptional long-term performance and cost-effectiveness of stainless steel architecture.

# Environmental Benefit of Stainless Steel

The environmental impact of construction materials is a growing concern. If appropriate grades and finishes are selected, there should be no need to replace stainless steel, even if the building life spans hundreds of years. Stainless steel scrap has a high value — so it is not discarded. Stainless steel is 100% recyclable and there is no limit as to how much recycled scrap can be used to produce new stainless steel.

Stainless fasteners and anchors help ensure that stone, masonry, pressure-treated lumber, slate, and tiles reach their full service life potential. It is also increasingly being used in remedial repairs of the existing building stock including historic buildings.

Metal loss due to corrosion can potentially add toxic elements to the environment and the lost metal can not be recycled. Replacing lost metal adds an additional environmental burden (energy consumption, mining, mineral extraction). The stainless steel examples in this brochure illustrate that, even in harsh environments, stainless steel corrosion losses are negligible.

Because stainless steels are inherently corrosion resistant, no protective coatings are needed, and the adverse environmental impact associated with coatings is eliminated (out gassing volatile organic compounds [VOCs], replacement, and removal for metal recycling). No acids or harsh chemicals are needed to clean stainless steel.

Gateway Arch, St. Louis, 1965  
*Courtesy of the U.S. National Parks Service*



It is important to select an appropriate stainless steel grade for the site. *Table 1* provides guidelines for grade selection. It is important to evaluate each site carefully. Localized pollution and the direction of the prevailing winds can cause differences in the corrosiveness of sites that are only a few miles or kilometres apart. Generally, locations within ten miles or 16 km of salt water are considered coastal for material selection purposes, but weather patterns can sometimes carry marine salts much further inland. The stainless steels most commonly used in architecture today are Types 304, 304L, 316, and 316L.

**Table 1 Suggested stainless steels for common exterior environments**

Location	Rural/Suburb			Urban			Industrial			Marine/Deicing Salt		
	L	M	H	L	M	H	L	M	H	L	M	H
<b>Higher Alloy Stainless Steels</b>	*	*	*	*	*	*	*	*	✓	*	*	✓
<b>316 or 316L</b>	*	*	*	*	✓	✓	✓	✓	(✓)	✓	✓	(✓)
<b>304 or 304L</b>	✓	✓	✓	✓	✓	(✓)	(✓)	(✓)	X	✓	(✓)	X
<b>430</b>	✓	(✓)	(✓)	X	X	X	X	X	X	X	X	X

L Least corrosive conditions (i.e. low humidity, low temperatures)

M Fairly typical of the category

H More aggressive corrosion likely (i.e. persistent moderate to high humidity, high ambient temperatures, aggressive air pollutants)

\* Generally provides good performance but may not be cost-effective due to higher cost

✓ Probably the best performance and cost choice

(✓) May be suitable if precautions are taken (i.e. a smooth surface and regular washing)

X Likely to suffer excessive corrosion

Unless there is regular manual cleaning, sheltered exterior areas can be more aggressive environments because rain cannot remove the corrosive deposits. At higher humidity levels, moisture in the air combines with corrosive chemicals in the deposits to form a highly concentrated corrosive solution. A more corrosion resistant stainless steel or more frequent maintenance may be needed to retain an attractive appearance. Exposed applications in environments with low or very light rainfalls and high humidity levels can also be aggressive because the rain does not remove deposits and moisture is present.

# Maintenance and Finish Selection

Highly alloyed stainless steels are sometimes needed for aggressive environments. Their corrosion resistance and characteristics vary and a corrosion specialist should be consulted to select an appropriate grade. The following examples of more highly alloyed austenitic grades are listed in order of increasing corrosion resistance: Type 317L (S31703), Type 317LMN (S31726), Alloy 904L (N08904), and the 6% molybdenum grades (i.e., S31254, N08367, N08926). Duplex stainless steels such as 2304 (S32304) and 2205 (S32205/S31803) may also be considered. The corrosion performance of 2304 is similar to that of Type 316, and 2205 is comparable to 904L and Type 317LMN.

Type 304 has replaced Type 302 in modern architectural applications. Although Type 302 was used in early coastal, polluted applications like the Empire State and Chrysler Buildings, neither Type 304 or 302 is suggested for coastal, polluted environments today. Designers are encouraged to use the conservative guidelines in *Table 1* to achieve desired appearance and life, and minimize maintenance. Additional information about grade selection and the performance of stainless steel relative to other architectural metals can be found in the NiDI publication 11 024: *Stainless Steel in Architecture, Building and Construction: Guidelines for Corrosion Prevention*.

Stainless steel looks best and provides maximum corrosion resistance when it is cleaned regularly. If dirt, grime and surface stains containing corrosive substances are left on the surface, corrosion may occur and routine cleaning is suggested to preserve stainless steel's appearance. When possible, designs should take advantage of natural rain-washing and include building washing systems.

Stainless steel is easy to clean and regular cleaning with appropriate products will not change the appearance of the finish over time. Loose dirt is rinsed off with clean water. A mild detergent or 5% ammonia and water solution is applied with a soft clean cloth. This is rinsed off with clean water and then wiped or squeegeed dry. A soft bristle brush can be used to loosen dirt and a degreaser to remove oil stains. Cleaning products should not contain chlorides or harsh abrasives. Most household cleaners should be avoided.

If the surface has been neglected or there are stubborn deposits, a mild, non-acidic, non-scratching, abrasive powder that does not contain chlorides or a suitable proprietary cleaning product can be used on bare stainless steel. More aggressive cleaning can damage some painted or coloured finishes and the supplier should be consulted before proceeding. Although buildings can often be restored to their original appearance after many years of neglect, remedial cleaning is more costly and can have uncertain results. Cleaning guidelines can be found in the NiDI publication 11 014: *Guidelines for Maintenance and Cleaning*.

# Maintenance and Finish Selection (cont.)

Both scientific studies and practical experience have shown that smoother finishes retain less dirt and debris, require less frequent cleaning, and provide improved performance in corrosive environments. Some of the buildings in this brochure used a stainless steel grade that would be considered inappropriate for the building's environment today and/or were not cleaned on a regular basis. Very smooth surface finishes (around  $R_a$  12 micro inches or 0.3 microns), designs that encourage natural rain washing, and plentiful heavy rain contributed to stainless steel's impressive performance in these buildings. A surface roughness of  $R_a$  20 micro inches or 0.5 microns or less is suggested for environments with high levels of particulate, corrosive pollution, and/or salt exposure and in applications where regular maintenance is unlikely. *Table 2* provides an international cross reference to common finishes and *Table 3* shows the range of surface roughness associated with those finishes in North America. The typical surface roughness range for a finish can vary from supplier to supplier and lighter gauges typically have smoother finishes than heavier gauges.

**Table 2 International cold-rolled sheet and strip surface finish cross reference**

USA (ASTM A480)	Japan (JSSA)	European (EN 10088)
<b>Mill Finishes</b>		
2D	2D	2D
2B	2B	2B
Bright annealed (BA)	BA	2R
<b>Polished Finishes</b>		
No. 3	No. 3	2G
No. 4	No. 4	2J
	No.240	2K
No. 7	No. 7	2P
No. 8		2P

*Note: These designations describe the production processes used to obtain the finish and are not visual standards. Within each surface finish designation, characteristics and appearance can vary. The manufacturer and purchaser must agree on more specific requirements.*



**Table 3 Typical sheet and strip surface roughness ranges from North American stainless steel suppliers**

ASTM A480 Finish Descriptions	R <sub>a</sub> and RMS Surface Roughness Equivalents			
	R <sub>a</sub> , micro-inches	R <sub>a</sub> , microns	RMS, micro-inches	RMS, microns
2D	5.0 – 39.0	0.13 - 1.0	6.4 – 49.2	0.16 – 1.25
2B	2.4 - 20.0	0.06 – 0.51	3.0 – 25.1	0.08 – 0.64
BA	0.5 – 4.0	0.01 – 0.10	0.49 – 4.9	0.01 – 0.13
#3	10.0 – 43.0	0.25 – 1.10	12.3 – 54.1	0.31 – 1.37
#4	7.0 – 25.0	0.18 – 0.64	8.9 – 31.5	0.23 – 0.80
6	12.0 – 18.0	0.30 – 0.46	14.8 – 22.6	0.37 – 0.57
7	2.4 – 8.0	0.06 – 0.20	3.0 – 9.8	0.07 – 0.25
8	0.74 - 4.0	0.019 - 0.10	0.9 – 4.9	0.02 – 0.13
Super No. 8	0.4 - 0.8	0.01 – 0.02	0.5 – 1.0	0.01 – 0.03
Hairline	5.5 - 8.0	0.14 – 0.20	6.9 – 9.8	0.18 – 0.25
Electropolished	4.0 - 16.0	0.10 – 0.41	4.9 – 20.2	0.13 – 0.50

*Note: Data for sheet and strip were obtained from North American finish suppliers. The highest and lowest values were used to create the surface roughness range and cover both light and heavy gauges. Lighter gauges generally have smoother finishes than heavier gauges. Surface roughness will vary across the width and length.*



150 East 42nd Street,  
New York City, 1954

Hiro Real Estate Company



# Savoy Hotel

LOCATION	1 Savoy Hill, London WC2 0BP, United Kingdom
DESCRIPTION	Stainless steel sign and sidewalk canopy for the Savoy Hotel which is in the Strand area of central London.
ENVIRONMENT	Near the coast, urban, and heavily polluted with coal fire smoke (sulphur compounds and high levels of particulate) until the late 1950's.
COMPLETED	1929
ARCHITECT	Sir Howard Robertson
OWNERS	Blackstone Group
ENTRANCE CANOPY	Single-story stainless steel marquee over the pavement (or sidewalk) with panels that are riveted in place.
Stainless steel	Type 302 stainless steel, 0.06 inch (1.5 mm) thick with a 'Staybrite' (buffed 2B) finish.
Maintenance	There is no routine maintenance schedule and it is cleaned infrequently. It was professionally chemically cleaned in 1989. The cleaning solution is unknown.
Condition	The famous 'Savoy' sign is in excellent condition. The marquee's alternating horizontally and vertically fluted panels trap dirt and are difficult to clean. Although discolouration occurs, there is no perforation of the stainless steel even at the junction with the adjacent building wall, which is one story higher and subject to rainwater run off.



February, 1930



The Savoy canopy in 1999



The Savoy canopy in 1999



A worker hand-cleaning the canopy

### SAVOY HOTEL DETAILS OF PROPOSED NEW ARCH TO SAVOY COURT

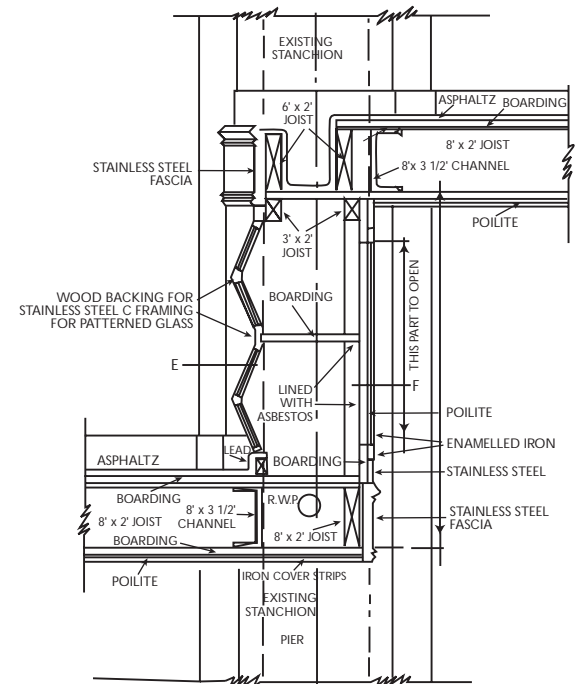
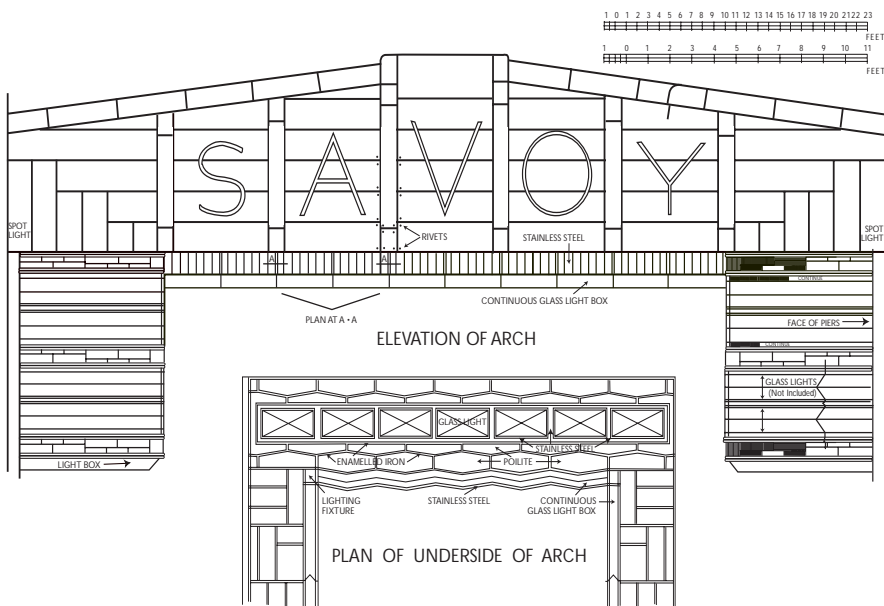

# Chrysler Building

LOCATION	405 Lexington Avenue, New York, New York
DESCRIPTION	In 1930, this icon of Twentieth Century classical and romantic tradition was the tallest building (77 stories, 1,048 ft or 319 m), largest masonry clad structure, and the first large, high-profile, stainless steel application in the world. The stainless steel gargoyles represent Chrysler hood ornaments and the stainless steel arches represent hubcaps. It is a Historic Landmark building.
ENVIRONMENT	Coastal, urban and heavily polluted for most of the building life.
COMPLETED	1930 (roof 1929)
ARCHITECT	William Van Alen
ROOF, SPIRE, AND GARGOYLES	Six rows of stainless steel arches were created using standing, batten, and flat lock seams and topped with a stainless steel spire. There are corner stainless steel gargoyles on the 31st and 61st floors.
Stainless steel	Type 302 stainless steel, 2B finish (brighter than today's 2B finish, average surface roughness $R_a$ 12 micro inches or 0.3 microns)
Fabricator/installer	B. Riesner, Inc.
Maintenance	It was cleaned in 1961 and 1995. The 1961 cleaning solution is unknown. A mild detergent, degreaser, and abrasive were used in 1995.
Repair/replacement	In 1995, a few damaged battens on the spire were replaced and several seams on the gargoyles were resoldered.
Condition	Very good. There are some small dents from the cleaning equipment and minor pitting above the flue pipe and on the 61st floor balcony. Neither adversely affected the roof integrity. The pitting could be removed with polishing.
ENTRANCE	Stainless steel and glass doors
Stainless steel	Type 302, No. 4 polished finish
Maintenance	Deicing salt caused minor pitting corrosion of the stainless steel, which was removed by polishing. A clear coating was applied to protect them. It is removed and reapplied annually.
OTHER APPLICATIONS	Mild steel brick ties had deteriorated in several locations and were replaced with stainless steel wall ties in 1995.

The Chrysler Building shortly after completion



Courtesy of the American Iron and Steel Institute



A worker cleaning one of the Chrysler Building gargoyles in 1961. The building has been cleaned twice, in 1961 and 1995.

Courtesy of the American Iron and Steel Institute



The stainless steel arches in 1996

Current photo of the Chrysler Building

Courtesy of Chrysler Building

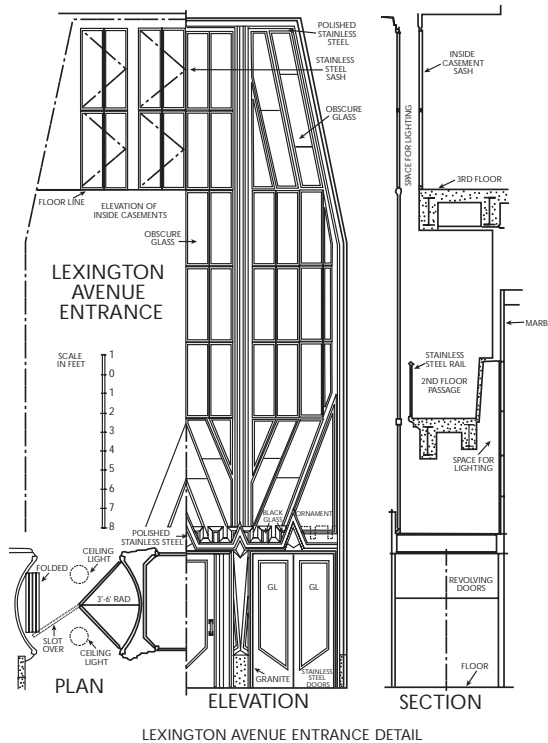
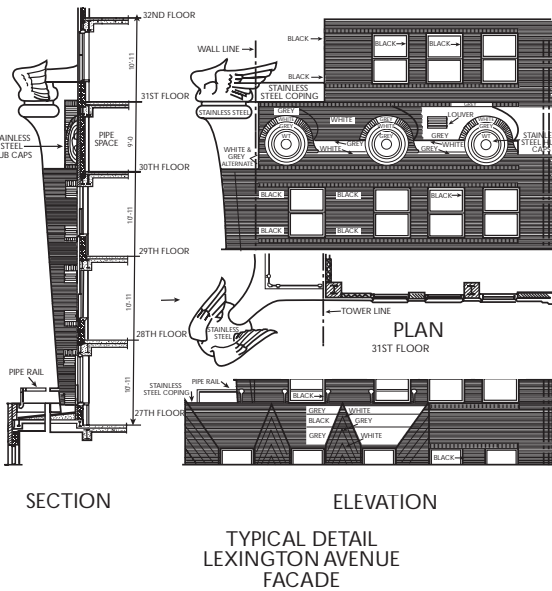

The entrance in 1996

# Empire State Building

LOCATION	350 Fifth Avenue, New York, New York
DESCRIPTION	This Historic Landmark building is 1,252 feet (382 m) tall with 85 stories of office space. It was the world's tallest building for 41 years. The 200 foot (61 m) dirigible mooring mast and five stories of office space were late design additions to surpass the Chrysler Building's height. The exterior is stainless steel, gray limestone, and dark gray aluminum.
ENVIRONMENT	Coastal, urban and heavily polluted for most of the building life.
COMPLETED	April, 1931
ARCHITECTS	Shreve, Lamb, and Harmon
OWNER	Helmsley-Spear, Inc.
STRUCTURAL ENGINEERS	Homer G. Balcom
GENERAL CONTRACTORS	Starrett Brothers and Eken
FABRICATOR	United Metal Products Co.
INSTALLER	C. E. Halback and Company and William H. Jackson Company.
SPANDREL PANELS	Vertical Type 302 stainless steel, 10 inch (254 mm) wide spandrel panels start on the sixth floor and extend upward outside each window group to form a sunburst at the top of each tier. There are 22 inch wide (559 mm) stainless steel mullions between each window. The stainless steel panels are bolted to brackets in the masonry wall and reinforced with Type 302 stainless steel channels every 2 feet (610 mm). The longest is 151.56 inches (3,849.6 mm). The dark panels underneath each window are cast aluminum.
Stainless steel	Over 300 metric tons of .05 inch (1.27 mm), Type 302 stainless steel with a No. 6 Tampico polish from Allegheny Steel Corporation and Republic Steel Corporation.
Maintenance	Cleaned in 1995. The cleaning method is unknown.
Repair/replacement	Some panels were replaced when an Air Force B-25 bomber crashed into the building in 1945.
Condition	Excellent. There have never been any problems with the stainless steel.
OTHER APPLICATIONS	Mooring mast and observation deck area used another 25 metric tons of Type 302 stainless steel.

Topping out the steel framing and completing exterior panel installation, September, 1930



Current photo of the Empire State Building

*Courtesy of Empire State Building managed by Helmsley-Spear, Inc.*



*Courtesy of the American Iron and Steel Institute*

Completed building with some scaffolding still in place, 1931



*Courtesy of the Skyscraper Museum of New York*



The spandrel panels and sunbursts in 1996

# General Electric Turbine Plant, Building No. 273

LOCATION	Schenectady, New York
DESCRIPTION	This four-story office building was the first significant stainless steel curtain wall application.
ENVIRONMENT	Industrial location that was initially highly polluted.
COMPLETED	The original building was built in 1948. There was a large addition in 1966. The lobby was renovated in 1992 and stainless steel wall panels and doors were added.
DESIGNER/CONTRACTOR	Stone & Webster Engineering Corporation
OWNER	General Electric Co.
CURTAIN WALL AND WINDOW FRAMES	The vertical square-ribbed corrugated or profiled stainless steel curtain wall panels are spot welded to the steel structural framing at 12 inch (305 mm) intervals. The welds are not visible. The same panel type, stainless steel, and finish were used for both the original building and addition and they are indistinguishable.
Stainless steel	Corrugated, 0.038 inch thick (0.97 mm), Type 302 stainless steel with a 2B finish
Fabricator/installer	Allegheny Metal Stainless Steel, Allegheny Ludlum Steel Corporation, Pittsburgh, Pennsylvania
Maintenance	Other than the entrance area, it has only been cleaned by natural rain washing.
Repair/replacement	None
Condition	Very good. Exposed wall panels are clean and uniformly silver-gray. Sheltered areas have some dirt accumulation. By the 1960's, the sealant around some of the windows had deteriorated and rust from carbon steel structural members behind the stainless steel was causing minor staining in a few locations. The sealant was replaced and the staining was removed. There have been no problems with the stainless steel.
Planned Renovation	A significant renovation of the building is planned to modernize the building systems. Since the stainless steel is in excellent condition, the panels will be removed, cleaned, and reinstalled. New embossed stainless steel panels will be installed around the entrance to modernize its appearance. Leo A. Daly Architecture is overseeing this environmentally friendly re-use of the stainless steel.



General Electric Turbine Plant, Building No. 273 in 1993



The original building and new addition are shown in this 1966 photo



Courtesy of the American Iron and Steel Institute

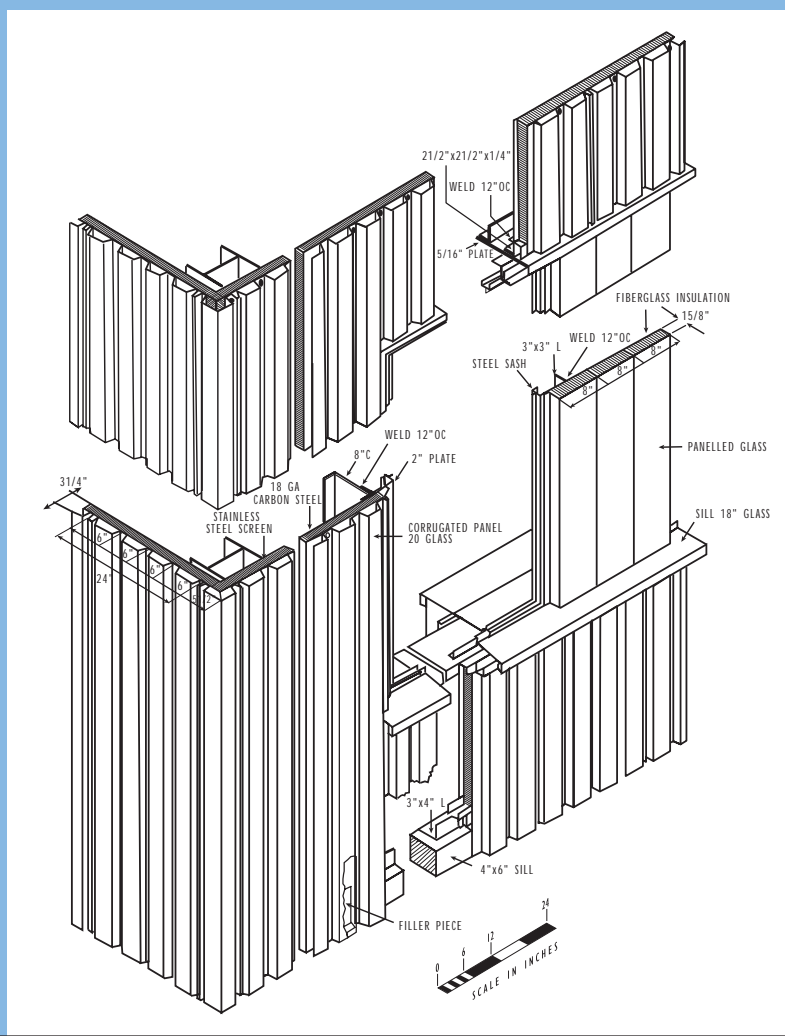

# 150 East 42nd Street

(Formerly the Socony Mobil Building)

LOCATION	150 East 42nd Street, New York, New York
DESCRIPTION	This 42-story office building was the world's largest metal clad building in 1954.
ENVIRONMENT	Coastal, urban environment with moderate to high pollution levels during the building life.
COMPLETED	1954
ARCHITECTS	Harrison, Abramovitz & Harris
OWNER	Hiro Real Estate Co.
CURTAIN WALL	The 4th through 42nd floors have pressed stainless steel panels joined with continuous vertical stainless steel battens that allow movement. Overlapping panels form the horizontal joints. The stainless steel frames for the enamelled panels at the base of the building have a No. 4 polish.
Stainless steel	340 metric tons of 0.038 inch thick (0.97 mm), Type 302 stainless steel, 2B finish, surface roughness of $R_a$ 12 micro inches or 0.3 microns
Fabricator/installer	Truscon Division, Republic Steel Corporation
Maintenance	Cleaned for the first time in 1995 with a proprietary neutral detergent, degreaser, and water solution.
Repair/replacement	Several panels were replaced due to air handling equipment changes.
Condition	Excellent. There have been no problems with the stainless steel.
OTHER APPLICATIONS	Window frames, entrance doors, elevator panels, and reception desk are stainless steel with a No. 4 polish and surface roughness of $R_a$ 47 micro inches or 1.2 microns.

Current photo of 150 East 42nd Street



Workers cleaning 150 East 42nd Street in 1995

Courtesy of J & L Specialty Steel

Erecting the wall panels



Courtesy of the American Iron and Steel Institute

Courtesy of Hiro Real Estate Company

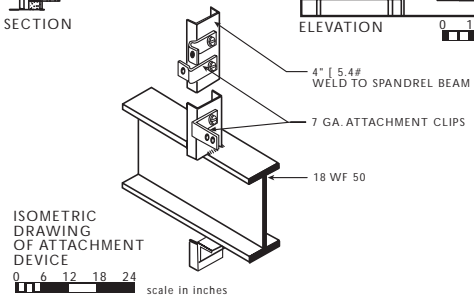
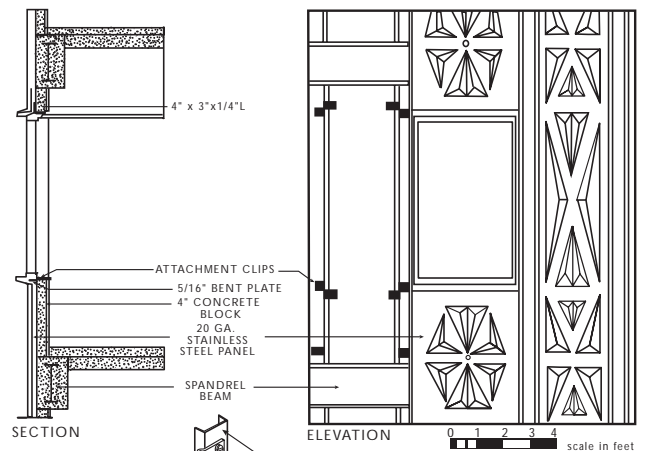
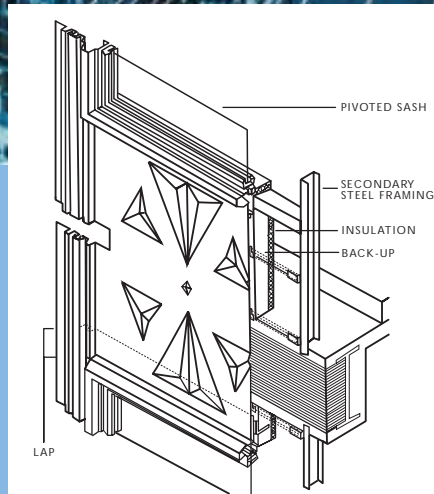

# Das Thyssenhaus

(Thyssen Building)

LOCATION	Thyssen Strasse, Dusseldorf, Germany
DESCRIPTION	This was one of the first steel framed, curtain walled, high-rise buildings in Europe. It has 24 stories and is 312 feet (95 metres) tall. Das Thyssenhaus is classified as one of Germany's important listed buildings.
ENVIRONMENT	Moderate, inland, urban location with exposure to saline aerosol or mist from a nearby road where deicing salt is used.
COMPLETED	1960
ARCHITECT	Prof. Dr. Ing. Hentrich
CURTAIN WALL	The east and west facades are aluminum curtain wall. The north and south facades are clad with stainless steel panels that have a trapezoidal profile or corrugation. Brackets were spot-welded to the back of the panels to attach them to the building's secondary framework. The brackets contain slots to facilitate alignment during erection. The panels interlock at their edges and the joints are sealed with mastic.
Stainless steel	0.06 inch (1.5 mm) thick Remanit 1880SW stainless steel (18%Cr, 10%Ni) with a polished finish (surface roughness of $R_a$ 12 micro inches or 0.3 microns)
Maintenance	Washed twice a year
Repair/replacement	The building had a major overhaul between 1992 and 1995 and the entire aluminum curtain wall was replaced. A few stainless steel panels at ground level were damaged by impact and replaced; otherwise there has been no stainless steel panel replacement.
Condition	The spot welds can be seen on the exterior face. This could be avoided with modern welding techniques. No corrosion is visible. The stainless steel cladding has retained its low reflectivity, high-quality appearance and is in excellent condition. The replacement panels are indistinguishable from the older ones.

Dusseldorf's  
Thyssenhaus as it  
appeared in 1956

Courtesy of Thyssen AG

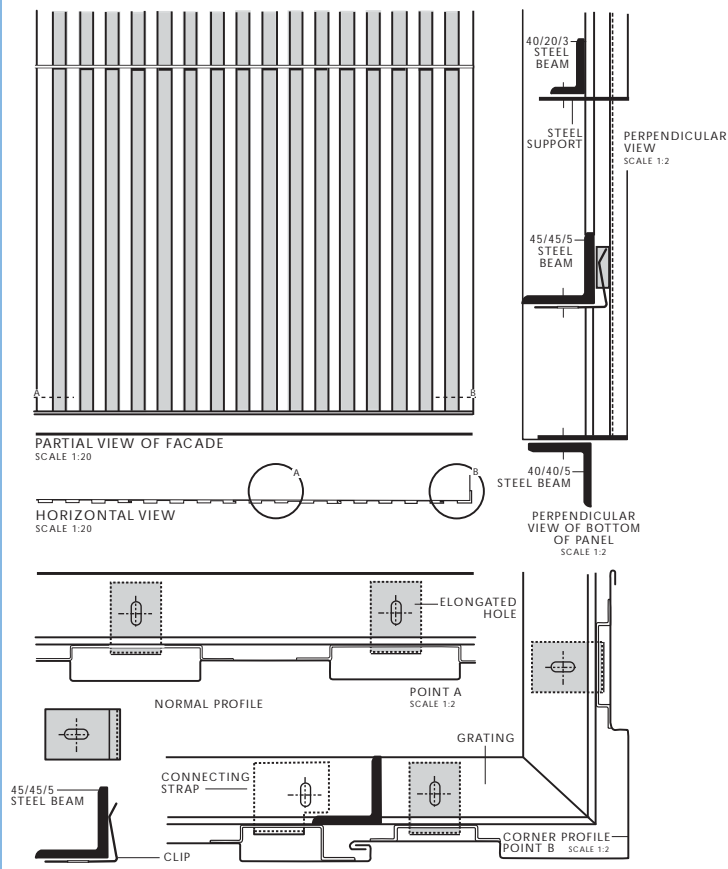

Stainless steel wall today

# Pittsburgh Civic Arena

LOCATION	Pittsburgh, Pennsylvania
DESCRIPTION	Public facility for professional hockey games and other sporting events, concerts, and conventions. When constructed, it had the world's largest dome and retractable roof. There are no interior supports.
ENVIRONMENT	This downtown location was heavily polluted in 1961. Pollution levels are now moderate.
COMPLETED	1961
ARCHITECTS	Mitchell & Ritchey Architects.
ENGINEERS	Ammann & Whitney, Engineers.
GENERAL CONTRACTOR	Dick Corporation
OWNER	City of Pittsburgh
ROOF	7,800 pieces of stainless steel were joined with flat lock and batten seams to form the eight movable leaves of the 170,000-ft <sup>2</sup> (15,793-m <sup>2</sup> ) dome roof. Insulation under the roof dampens sound and controls temperature. The stainless steel dome is 415 ft (126 m) in diameter and 136 ft (41 m) high and can be opened in two minutes.
Stainless steel	2,950 tons of 0.0625, 0.0375, and 0.031 inch thick (1.59, 0.95, and 0.79 mm), Type 302 stainless steel, 2D finish from US Steel, J&L Specialty Steel, Cyclops, and Allegheny Ludlum.
Fabricator/installer	Limbach Company
Maintenance	It was cleaned once in the early 1980's. The cleaning method is unknown.
Condition	Excellent. There have been no problems with the stainless steel. The directionality of the finish was used to create a design on the roof. The pattern is not uniform because there were several stainless steel suppliers and there were slight finish variations.

A current photo of the Pittsburgh Civic Arena



Courtesy of Pittsburgh Civic Arena

The Pittsburgh Civic Arena in 1970



Courtesy of Washington Steel

ROOF DETAILS

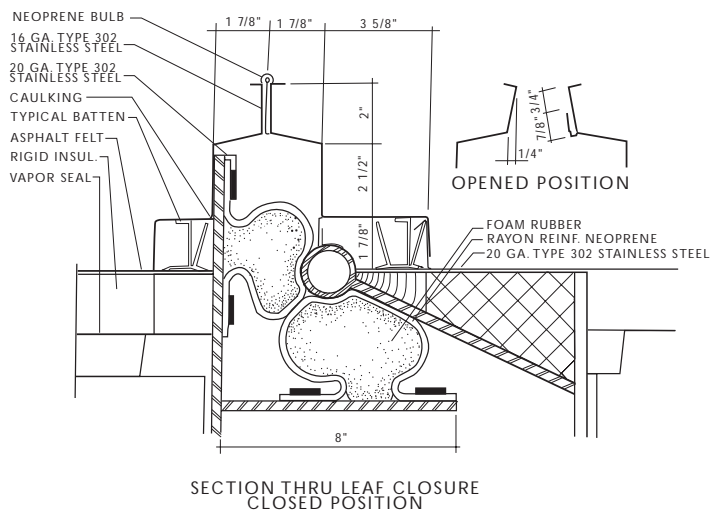
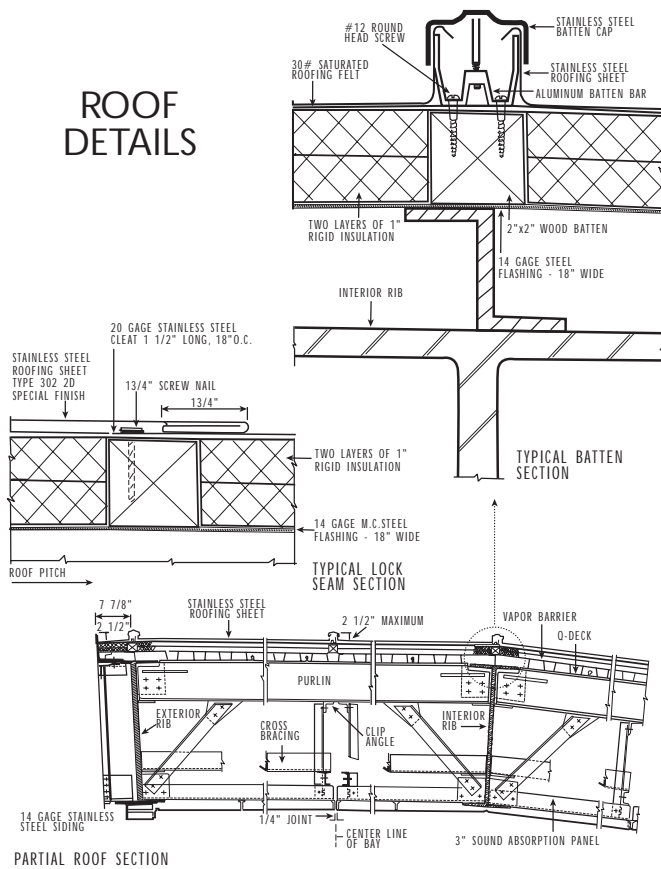

# Elephant & Castle Sub-station

LOCATION	Newington Causeway, London, United Kingdom
DESCRIPTION	This single-story listed building is protected from modification. It is in central London on the southern side of the Thames River and houses an electrical sub-station.
ENVIRONMENT	Near the coast in an urban location that is exposed to dust and high levels of vehicle emissions.
COMPLETED	1962
ARCHITECT	London County Council
CONTRACTOR	Morris Singer (now Crittal Construction Ltd.)
OWNERS	London Transport
CURTAIN WALL	Stainless steel exterior wall panels with a pressed pattern
Stainless steel	Type 316 stainless steel, 0.028 inch (0.711mm) thick with a 'Staybrite' (buffed 2B) finish produced by Firth Vickers (surface roughness R <sub>a</sub> 12 micro inches or 0.3 microns)
Maintenance	No cleaning was planned and none has been done.
Condition	Excellent. The stainless steel is shiny and stain-free with some minor dents. Natural rainwater washing has prevented accumulations of airborne contaminants.





These 1999 photos of the Elephant & Castle Sub-Station illustrate that industrial buildings can remain attractive and relatively clean if an appropriate stainless steel and a smooth surface finish are specified. The design encourages natural rain cleaning and there is plentiful rain.

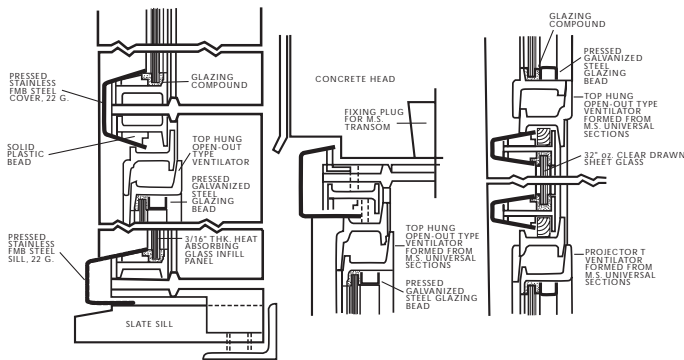
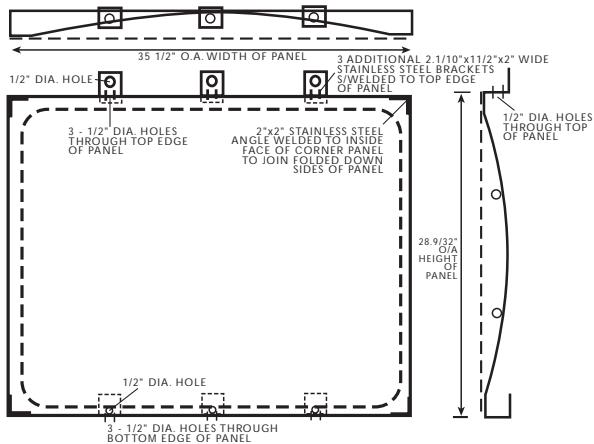

# Gateway Arch

LOCATION	Jefferson National Expansion Memorial, St. Louis, Missouri
DESCRIPTION	Exterior stainless steel and the interior mild steel plates carry the structural and wind loads. In 1965, it was the largest stainless steel structural application in the world. It is the tallest memorial in the United States at 630 feet (192 m).
ENVIRONMENT	Urban with moderate pollution levels
COMPLETED	1965
ARCHITECT	Eero Saarinen and Associates
STRUCTURAL ENGINEERS	Severud, Elstad, Krueger and Associates
CONTRACTOR	MacDonald Construction Company
FABRICATOR/INSTALLER	Pittsburgh - Des Moines Steel Company
OWNER	United States National Parks Service
EXTERIOR	Type 304 stainless steel plates were welded together and cut to size. Type 304 stainless steel studs (0.31 inch or 7.9 mm) were welded to the back and steel Z-bars were attached. Below 300 feet (91 m), high strength steel bolts were attached to the Z-bars, passed through the concrete core and carbon steel inner skin, and held in place with carbon steel nuts. Above 300 feet (91 m), vertical steel diaphragms connect the skins, serve as stiffeners, and prevent buckling.
Stainless steel	904 metric tons, 0.25 inch thick (6.3 mm) plate, Type 304 stainless steel with a No. 3 polished finish supplied by US Steel and Eastern Stainless Steel Corporation
Maintenance	Graffiti is removed from the base. Otherwise, it is washed by rain.
Condition	Very good. There is a checkerboard effect because of differences in polishing direction. The structural load caused some minor buckling giving it a slightly wavy appearance.
Reasons for selection	Saarinen wanted the arch to last 1000 years and said, "Having arrived at a shape that seemed to have permanence and to belong to our time, what material would also fulfill those two qualities? Stainless steel seemed the inevitable answer - and so we decided on stainless steel with a concrete core."



Construction of the Gateway Arch



Courtesy of the National Parks Service



Current photo of the Gateway Arch

Courtesy of the National Parks Service

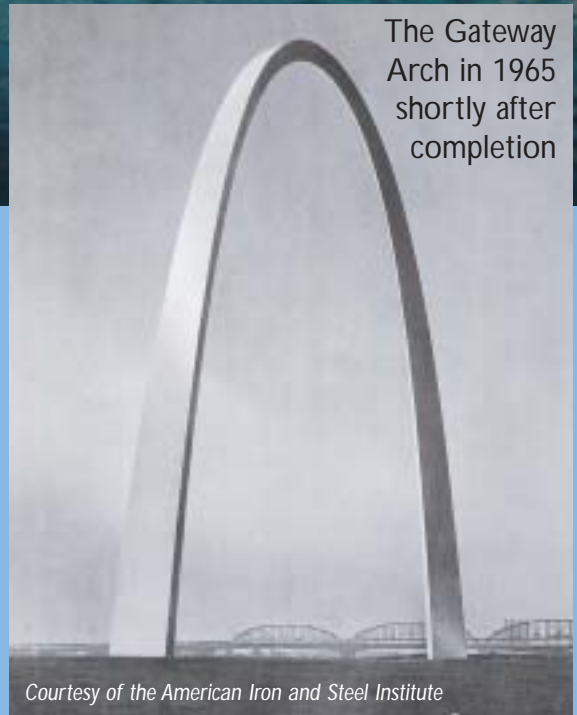
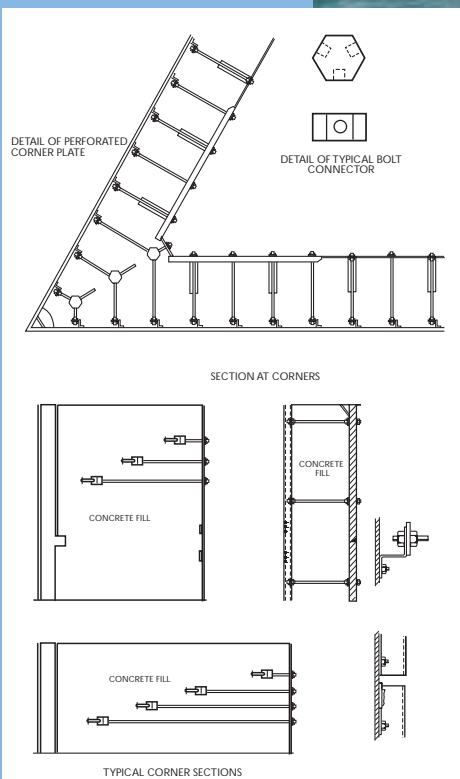

The Gateway Arch in 1965 shortly after completion

Courtesy of the American Iron and Steel Institute

# Lewisham Civic Centre

LOCATION	Catford Road, Lewisham, London SE6, United Kingdom
DESCRIPTION	Three-story local government office building
ENVIRONMENT	Near the coast in an urban location that is exposed to heavy automotive pollution and dust.
COMPLETED	1971
ARCHITECT	Lewisham Borough Architects
CONTRACTOR	Culford Metal Industries
OWNERS	Lewisham Borough Council
CURTAIN WALL	The second and third floors have stainless steel mullions, rails and spandrel panels.
Stainless steel	Type 316 stainless steel
Maintenance	The maintenance department has no record of ever cleaning the building.
Condition	The stainless steel is quite dull in appearance. There is some visible discolouration, which appears to be dirt accumulation that could be removed by cleaning. There is no visible corrosion.



The Lewisham Civic Centre has never been cleaned and dirt accumulation is evident in these 1999 photos. No corrosion is visible and cleaning would restore the building to its original appearance.



# Kearns Communications Group Building

(Formerly the Homestead Federal Savings and Loan Association)

LOCATION	33 East Second Street, Dayton, Ohio
DESCRIPTION	Small, three-story office building. The distance between the two long walls increases to give the building a triangular appearance, although it has four sides.
ENVIRONMENT	Downtown location with moderate pollution levels and winter deicing salt exposure.
COMPLETED	1973
ARCHITECTS	Levin Porter Associates
OWNER	33 East, Ltd.
CURTAIN WALL	Two sides of the building have stainless steel curtain walls with no windows. The other two sides are glass curtain walls and doors with solid stainless steel framing.
Stainless steel	The curtain wall is Type 304, 0.109 inches (2.76 mm) thick with a No. 4 polish from Washington Steel. The framing is extruded Type 304.
Fabricator/installer	Overly Manufacturing Company
Maintenance	Cleaned several times a year when the windows are cleaned.
Repair/replacement	None
Condition	Excellent. Tree branches lightly scratched several panels above pedestrian eye level. The trees were removed and replaced with smaller varieties. No corrosion or damage from passing pedestrians was observed.

Kearns Communications Group Building in 1999



Edward Madden, Kearns Communications Group

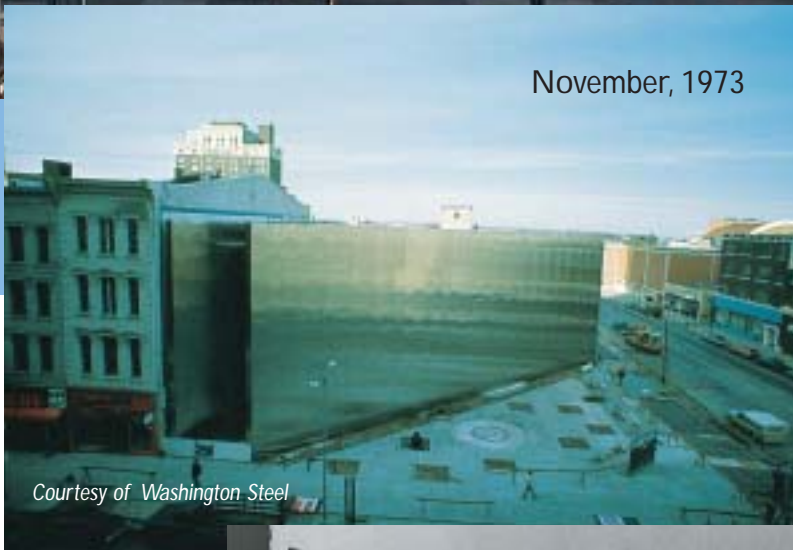

November, 1973

Courtesy of Washington Steel

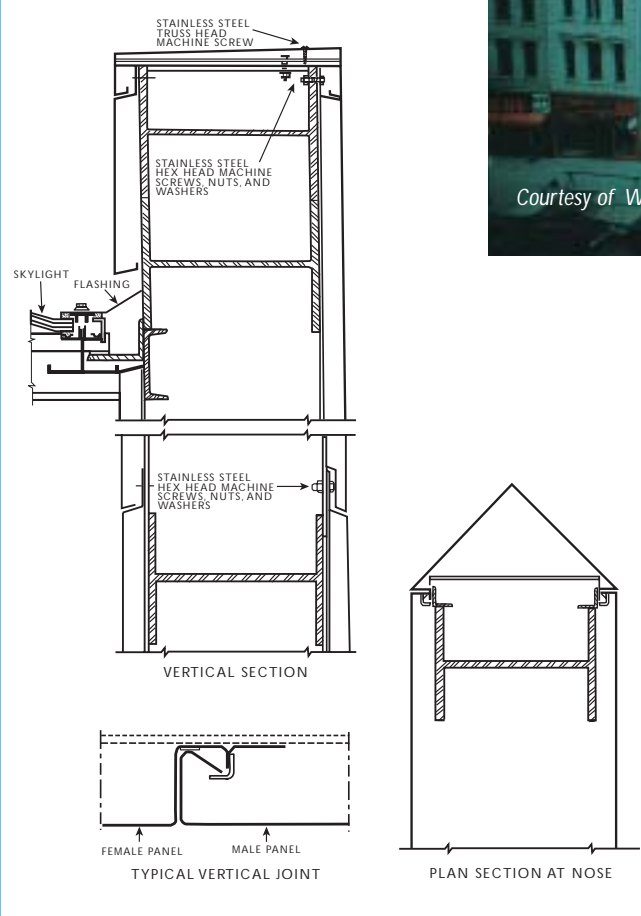

An evening shortly after completion in 1973

Courtesy of the Overly Manufacturing Company, Greensburg, Pennsylvania

# Enfield Civic Centre

LOCATION	Enfield, Middlesex, United Kingdom, which is on the northeast outskirts of London, approximately one mile inside the M25 motorway.
DESCRIPTION	Twelve-story local government office building
ENVIRONMENT	Near the coast in a moderate, urban location set back from a busy street.
COMPLETED	1973
ARCHITECT	Enfield Borough
OWNERS	Enfield Borough Council
CURTAIN WALL	The bright annealed and embossed stainless steel exterior cladding is held in place by screws stud-welded to the back of the panels.
Stainless steel	100 metric tons of 0.06 inch (1.5 mm) thick Type 316 stainless steel with either a bright annealed (BA) or an embossed (Rimex 6WL) finish.
Maintenance	None
Condition	The stainless steel has a dull appearance. There is superficial staining on the lower panels. Despite the lack of recommended maintenance, it is in good condition. Cleaning would restore it to its original appearance.





The Enfield Civic Centre has never been cleaned. Although some dirt accumulation is visible in this 1999 photo, the building is still attractive. Cleaning would restore the panels to their original appearance.



Enfield Civic Centre  
in 1999



Enfield Civic Centre  
in 1976

*Courtesy of Barry Gould Photography*



The wall panels have an embossed finish and the window frames have a bright annealed finish.

# Pier Pavilion

LOCATION	Herne Bay, Kent, United Kingdom
DESCRIPTION	A two to three-story sports centre on the end of an ocean pier.
ENVIRONMENT	A low-pollution, severe marine environment with seawater spray exposure.
COMPLETED	1976
ARCHITECT	John C. Clague
CONTRACTOR	H. H. Robertson Ltd.
OWNERS	Herne Bay County Council
CURTAIN WALL	The external corrugated or profiled stainless steel cladding has a trapezoidal cross section and is held in place with stainless steel rivets.
Stainless steel	Type 316 stainless steel with a 2B finish (surface roughness of $R_a$ 14 micro inches or 0.35 microns)
Maintenance	No cleaning was intended and none has been carried out.
Repair/replacement	Some stainless steel panels were replaced due to accidental damage when equipment was lifted into the building by crane. The newer stainless steel panels are visibly cleaner than the older panels.
Condition	Despite the lack of recommended maintenance and the direct exposure to seawater spray which deposits salt on the stainless steel, it is in very good condition. There is some superficial staining. Although this is clearly visible at close range, it is not obvious from the shore end of the pier. The staining could be removed by cleaning. There is staining around some but not all of the rivets. Different rivet materials may have been used. The building has a mixture of exposed and roof-overhang-sheltered stainless steel cladding. The sheltered areas are not washed by the rain and have more dirt and salt deposits.

Pier Pavilion  
in 1999



The Pier Pavilion has never been cleaned and it is splashed with seawater spray. There is some superficial corrosion staining, particularly in sheltered areas that are not washed by rainwater. Regular cleaning would remove the stains and prevent recurrence.

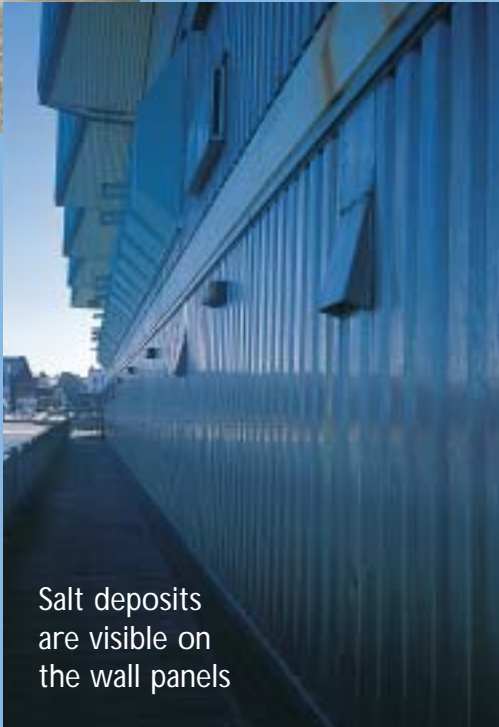

Salt deposits  
are visible on  
the wall panels

Pier Pavilion has large eaves  
that limit rainwater washing.



# ICI Building

(Formerly CIL House)

LOCATION	90 Sheppard Avenue East, North York, Ontario, Canada
DESCRIPTION	Seven-story, 267,000 ft <sup>2</sup> (24,805 m <sup>2</sup> ) office building
ENVIRONMENT	Park-like setting in suburban Toronto with moderate pollution levels and building entrance deicing salt exposure.
COMPLETED	1981
ARCHITECTS	Shore Tilbe Hewschel Irwin Peters
CURTAIN WALL	An early rain screen design was used for the stainless steel horizontal spandrel panels, seventh floor parapet and outrigger spandrel panels, and roof penthouse cladding.
Stainless steel	Type 304 stainless steel, 0.109 inches thick (2.76 mm) with an Imperial finish from Atlas Stainless Steels, Canada (rough, embossed finish with a surface roughness of R <sub>a</sub> 130 micro inches or 3.3 microns)
Fabricator/installer	Antamex, Inc.
Maintenance	Cleaned for the first time in 1991 and annually since then with a mild detergent, water, and degreaser solution.
Repair/replacement	None
Condition	Very good but the rough finish collects more dirt and debris between cleanings than a smoother finish would.
ENTRANCE DOORS	Four entrances with stainless steel revolving doors.
Stainless steel	Type 304 stainless steel, No. 8 polish, surface roughness R <sub>a</sub> 12 micro inches or 0.3 microns
Door manufacturer	C. J. Rush Rovico
Maintenance	Cleaned quarterly with a non-abrasive, non-acidic stainless steel cleaner and coated with a clear wax and petroleum mixture to hide fingerprints.
Condition	Excellent
OTHER APPLICATIONS	Exterior stainless steel balcony railings and gravel stops.

# ICI Building in 1981



Courtesy of Shore Tilbe Irwin & Partners

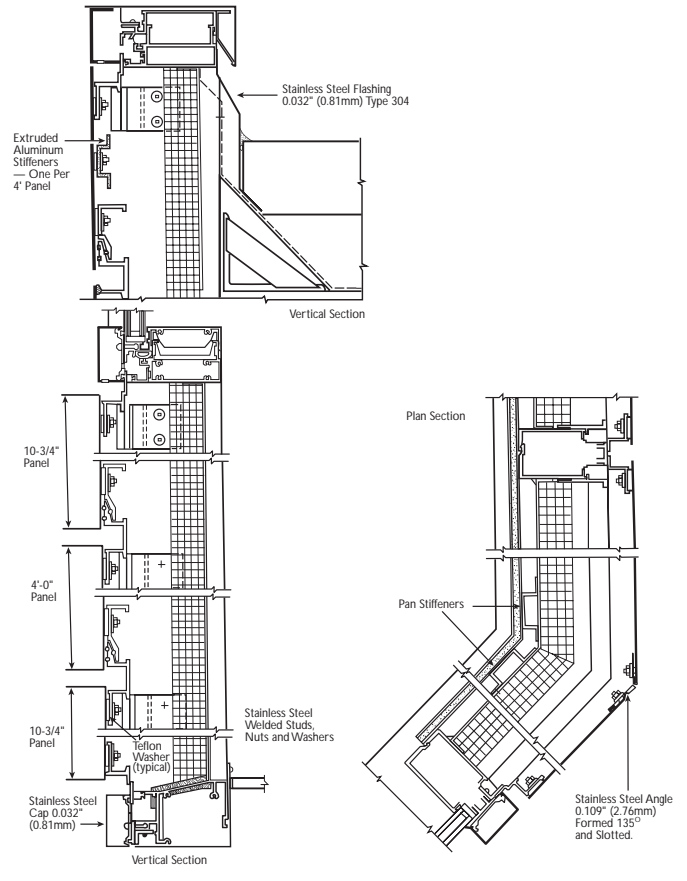

# Sun Life Centre

LOCATION	150 King Street West, Toronto, Ontario, Canada
DESCRIPTION	High-rise office building with two towers.
ENVIRONMENT	Downtown location with moderate pollution levels and deicing salt exposure.
COMPLETED	1984
ARCHITECTS	Webb Zerafa Menkes & Housden Partnership
GENERAL CONTRACTOR	Eastern Construction
OWNER	Sun Life Assurance Co. of Canada
STAINLESS STEEL	All components are Type 304 stainless steel with a Bright Imperial finish from Atlas Stainless Steels, Canada (rough, embossed, average surface roughness $R_a$ 62 micro inches or 1.25 microns).
CURTAIN WALL	The stainless steel horizontal face panels are 0.06 inches (1.5 mm) thick and the stainless steel mullions are 0.03 inches (0.8 mm) thick.
Fabricator/installer	Kawneer Co. of Canada Ltd.
Maintenance	The exterior is cleaned three to four times per year with proprietary neutral detergents and water. In the spring, a mild abrasive cleaner is used to remove residual deicing salts, other surface contaminants, and any discoloration caused by deicing salts. Deicing salt and dirt from the roads have been found as high as the twelfth floor.
Condition	Excellent
ENTRANCE CANOPIES AND EXTERIOR COLUMN COVERS	The canopies are glass. There is Type 304 stainless steel cladding on the canopy framing and column covers.
Fabricator/installer	C. J. Rush
Maintenance	Cleaned biweekly
Condition	Excellent other than some minor dents at ground level.
OTHER APPLICATIONS	Stainless steel signs, lobby ledges, and fire hose bibs are cleaned biweekly and escalators are cleaned every two weeks.
Condition	Excellent



Sun Life Centre in 1999



The stainless steel is cleaned three to four times per year when the windows are cleaned

Sun Life Centre in 1983

Courtesy of Webb Zerafa Menkes & Housden Partnership

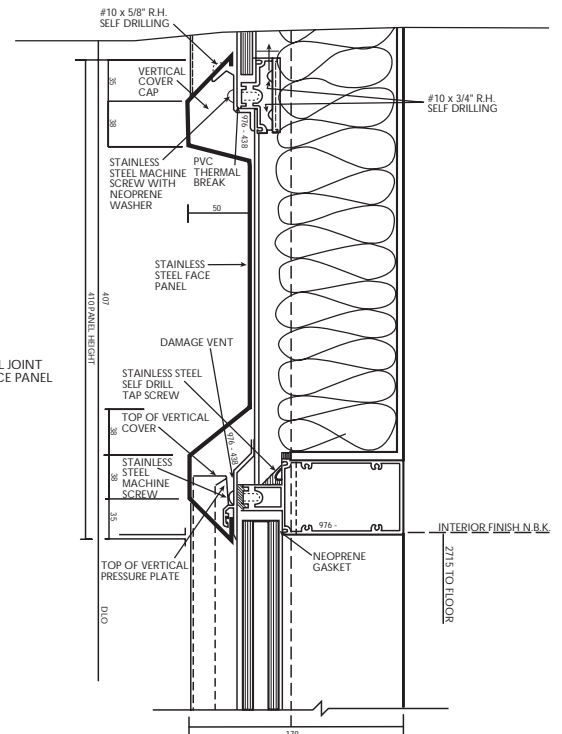
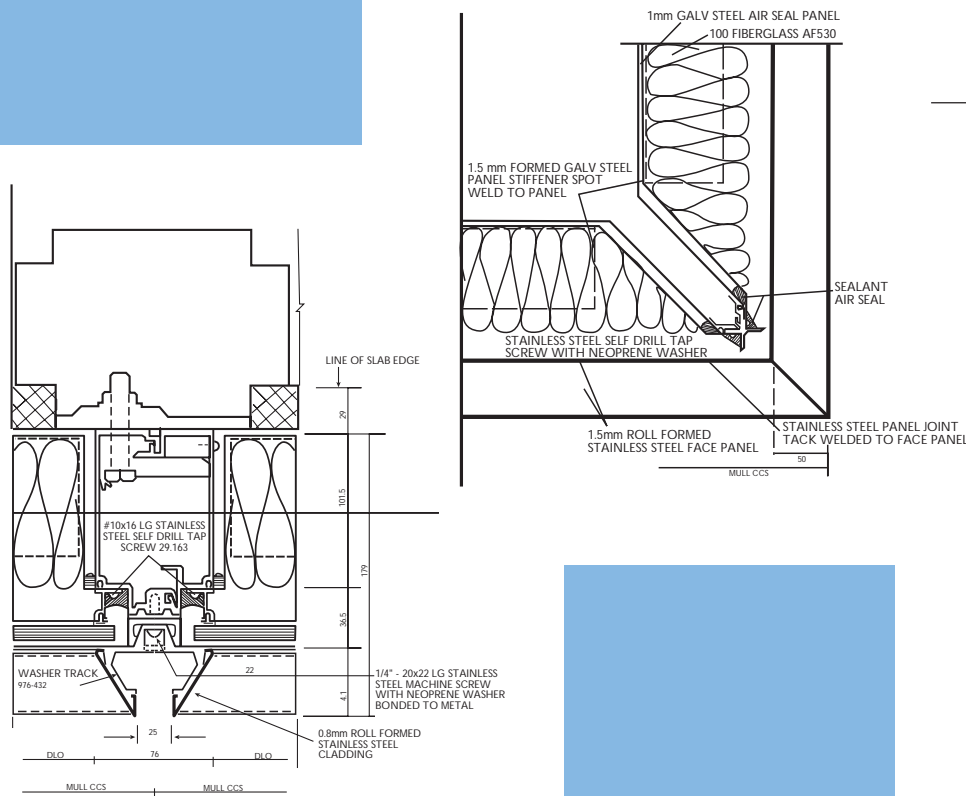

# Michael Fowler Centre

LOCATION	Wellington, New Zealand
DESCRIPTION	A concert hall and convention centre adjoining the bay.
ENVIRONMENT	A damp, severe marine environment with moderate pollution levels and regular moderate to high winds from the ocean.
COMPLETED	1985
ARCHITECT	Warren Mahoney
ROOF AND WALL PANELS	Curved stainless steel panels cover the top and bottom of the protruding circular centre of the building. There are also vertical stainless steel sunshades between the windows.
Stainless steel	Type 316L stainless steel with a No. 4 polish
Repair/replacement	Marine salt is deposited on the building by the wind. Initially no provision was made for cleaning. The sheltered panels are not washed by rain. Within a short period of time, there was pitting corrosion in sheltered areas. The pits were removed by polishing and the building was retrofitted with a cleaning system.
Maintenance	The panels are cleaned with a dilute solution of oxalic acid and detergent with a water rinse at least three times per year.
Condition	Regular cleaning eliminated the corrosion and the building owners are happy with the stainless steel.



Michael Fowler  
Centre in 1985



Michael Fowler  
Centre in 2000



# Acknowledgements

We would like to acknowledge the assistance provided by the following firms, local and national government branches, and museum:

Allegheny Ludlum Corporation

Cancore Building Services, Ltd.

Chrysler Building

Excelsior Steel Polishing

Helmsley-Spear, Inc.

Hiro Real Estate

ICI Building

J & L Specialty Steel

Kawneer Company of Canada Ltd.

Lewisham Civic Centre

Pittsburgh Civic Arena, City of Pittsburgh

RIMEX Metals, Inc.

Shore Tilbe Hewschel Irwin Peters

Skyscraper Museum of New York

Sun Life Assurance Co. of Canada

United States National Parks Service

Webb Zerafa Menkes & Housden Partnership

Without their assistance in obtaining information, providing site tours, photos, and/or architectural drawings, this brochure would not have been possible.

The authors would also like to thank the Nickel Institute for its support in the development of this publication and everyone who contributed to it through their comments and research, particularly Paul Pittsford, Les Boulton, Bill Brokenshire, Herbert Lawson, and Dr. James D. Redmond.

# NiDI Architectural Literature

The Nickel Institute has numerous publications to assist architects, designers, fabricators, and contractors who want to use stainless steel in architecture. Many of these publications can be downloaded from the NiDI website ([www.nidi.org](http://www.nidi.org)). An Architectural Library CD and hard copies of literature can be ordered on the website or by calling NiDI. Some of these publications are:

- 10 010      Architecture — A Demanding Market for Stainless Steel
- 10 037      Stainless Steel in Architecture
- 10 042      Stainless Steel for Durability, Fire-Resistance and Safety
- 11 013      Stainless Steel in Architecture, Building and Construction –  
Guidelines for Roofs, Floors and Handrails
- 11 014      Stainless Steel in Architecture, Building and Construction –  
Guidelines for Maintenance and Cleaning
- 11 015      Stainless Steel in Architecture, Building and Construction –  
Guidelines for Building Exteriors
- 11 024      Stainless Steel in Architecture, Building and Construction –  
Guidelines for Corrosion Prevention
- 12 004      Answers for Architects Who Design for Beauty,  
Performance, Utility and Prestige with Nickel Stainless Steel
- 14 043      Steeled Against the Elements (Doors)
- Reprint      Preserving Pittsburgh's Heritage
- Reprint      Asian Attractions: Award-Winning Stainless Steel  
Architecture
- Reprint      An Explorer of Possibilities, Master Architect, Frank O. Gehry